

611 direct immersion RTD assembly

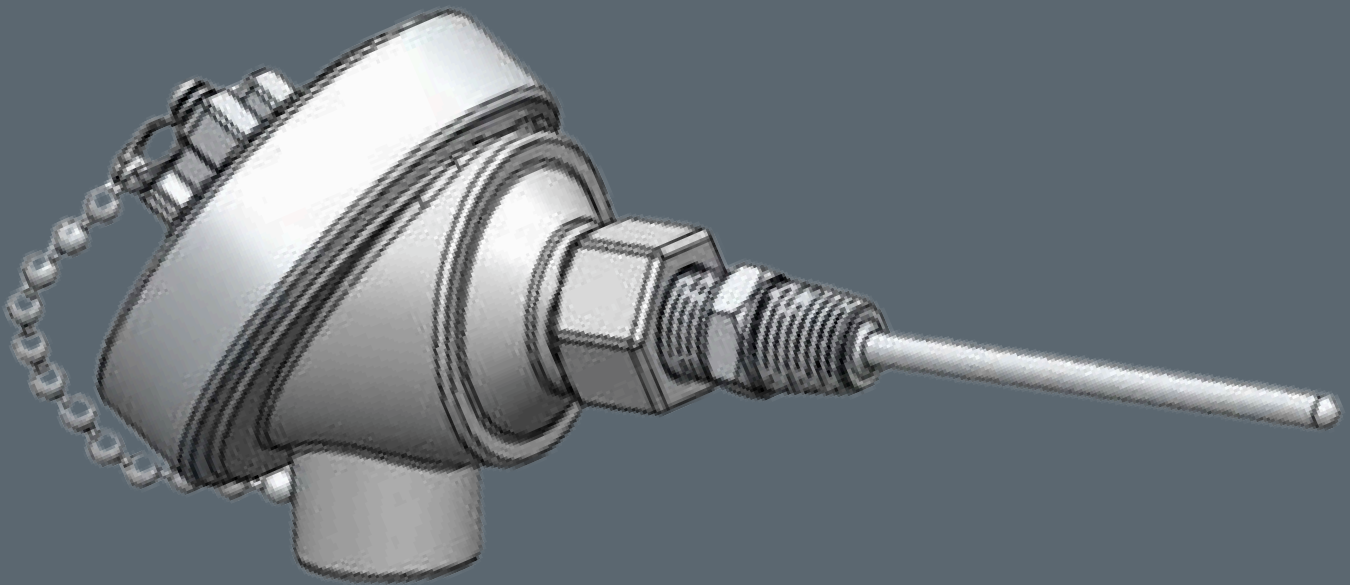

Key features

- Direct immersion nuclear applications
- Typical applications include duct mounting, tank pool or vessel mounting
- Threaded connection for mounting
- Pressure tight joint to the process application
- Qualified for use in Class 1E harsh environments

Overview

The model 611 series RTD is designed for a wide range of direct immersion nuclear applications requiring a threaded connection for mounting. This sensor is supplied with a threaded hex fitting which is welded to the sensor sheath to provide physical mounting and a pressure tight joint to the process application. This RTD electrical interface can be configured for use with a connection head and terminal block or Quick Disconnect Electrical Connector (QDC). Typical applications include duct mounting, tank, pool or vessel mounting. The RTD is qualified per IEEE 323-1974/1983 and IEEE 344-1975/1987 for use in Class 1E harsh environments, but can also be used for non-safety applications.

Technical specification

Feature	Description
Maximum operating temperature	0°F to 750°F (-18°C to 400°C)
Element type	Platinum (wire-wound)
Accuracy/interchangeability	IEC 60751 Class B is standard. IEC 60751 Class A is available upon request. Other special accuracies are also available.
Calibration points	Standard calibration points are 32° and 212° (0° and 100°)
Drift/stability	Sensor drift is less than ±0.2°F (±0.11°C) shift per year up to a maximum of 0.5°F (0.28°C) for the qualified life. These values were determined based on pre and post qualification test data.
Insulation resistance	At room temperature and dry external surfaces, the insulation resistance between any wire and the sensor case will be at least 100 MΩ with 100 VDC applied for a minimum of 30 seconds prior to measurement.
Response time	The response time for the bare sensor is approximately 5 seconds or less for the standard version with 1/4" diameter sheath as verified by a plunge test in accordance with ASTM E644 for a 63.2% of a step change from room temperature air to water flowing transverse to the assembly at 3 ft/s (~1m/s) at 180°F. Response time will vary depending upon final configuration, fit and actual process conditions.
Operating current	Standard operating current is 1 to 4 mA continuous. A continuous current of 20 mA (RMS) or less will not damage the sensor. A short duration or pulsed current of 40 mA maximum will not damage the sensor.
Self-heating error	In 154°F (68°C) water flowing transverse to the sensor sheath at 3 ft/s (~1 m/s), with a sheath diameter of 0.25 inches (6.35 mm), the RTD is capable of dissipating 10 mW/°C without causing the indicated temperature to rise more than 0.36°F (0.2°C).

Technical specification

Feature	Description
Qualification	RTD assemblies are qualified to Class 1E requirements of IEEE 323-1974/1983 and IEEE 344-1975/1987. Original qualification reports are 548-8854-001 and 06-8680-003.
Quality standards	RTD assemblies are supplied in accordance with Ultra Electronics Energy QA/QC Quality Assurance & Control Manual 100-1 which meets the requirements of 10 CFR 50 Appendix B, 10 CFR Part 21, ISO 9001, ASME NQA-1 and ANSI N45.2.
Sheath material	Stainless steel
External leadwire material	Stranded constantan insulated with polyolefin
Sheath internal insulation	MgO
Internal leadwire material	Solid constantan
Mounting connections	The RTD can be directly mounted to the process via the 1/2" NPT connection threads or incorporate the use of extension pipe fittings and unions. The terminal head conduit port has 3/4" NPT female threads as standard. The QDC will normally have 1/2" NPT male threads. Custom mounting connections are available upon request.
Terminal block material, if applicable	Ceramic
Quick disconnect electrical connector (QDC), if applicable	Quick disconnect bayonet (Gen 1 or Gen 3)
Shipping weight	Approximately 5lbs without QDC and 6lbs with QDC. Actual weight will depend upon configuration supplied.
Identification tags	SS identification tag attached to the terminal head using SS braided cable. Custom configured tagging is available upon request.

Technical specification

Feature	Description
Storage requirements	RTDs are to be stored in accordance with ANSI N45.2 Level B requirements or better.
Accessories	
Silicone sealant	Item No. 0102-004-0012T
P1 thread sealant	Item No. 0109-001-0113T
PST 580 thread sealant	Item No. 0109-001-0114T
Viton gasket for terminal head	Item No. 0322-001-0023T
6-Wire terminal block	Item No. 0308-004-0006T
8-Wire terminal block	Item No. 0308-004-0009T
Terminal head - general purpose single port	Item No. 0342-002-0016T
Terminal head - general purpose dual port	Item No. 0342-002-0017T
QDC O-ring	Item No. 0322-001-0070T

Technical specifications

Model number configurator

611	Model 611 Direct Immersion RTD Assembly																	
	Code	Element Style																
	S	Single Platinum Element, 4 Wire Configuration																
	D	Dual Platinum Element, 6 Wire Configuration																
	E	Dual Platinum Element, 8 Wire Configuration																
	X	Other - Consult Factory																
		Code	Resistance at 32°F (0°C)															
		1	100 Ohms															
		2	200 Ohms															
		X	Other - Consult Factory															
		Code	Temperature Coefficient (Ohms/Ohm/°C)															
		A	0.003902															
		B	0.00385055															
		X	Other - Consult Factory															
		Code	Temperature Range															
		A	500°F [260°C] Maximum															
		C	750°F [400°C] Maximum															
		Code	Number of Lead Wires															
		4	4-Wire Connection (Note: Can also be used as a 3-wire connection.)															
		6	Dual Element, 3-Wire Connection															
		8	Dual Element, 4-Wire Connection															
		Code	Sheath Diameter															
		C	0.250" [6.4 mm]															
		F	0.375" [9.5 mm]															
		X	Other - Consult Factory															
		Code	Sheath Length (L)															
		XXX.X	Length to Nearest 0.1" [2.5 mm] (Minimum is 2.0" [50.8 mm])															
		Code	Lead Length (Inches)															
		A2	1/2" NPT Hex Nipple - 316 Stainless Steel															
		X	Other - Consult Factory															
		Code	Lead Length (Inches)															
		0	Standard with head (Approximately 4") Note: The number zero (0) and the letter "O" are interchangeable for this code															
		ZXX	Other - Use XX to list length to nearest inch															
Head/Ext. Code	/	611	S	-	1	B	-	C	-	4	-	C	-	012.0	-	A2	-	0

Note: See the Model 611 Terminal Head and Extension Code Configurator to determine the appropriate Head/Ext. Code.

Technical specifications

Head/extension code configurator

8	Stainless Steel
X	Other - Consult Factory
	Code Extension Style & Material
A	Direct Assembly (1/2" NPT Male Mounting Threads are Typical)
E	Union Extension (1/2" NPT Female Mounting Threads)
J	Union/Nipple Extension - 316 Stainless Steel, 2.5" Minimum
X	Other - Consult factory
	Code Extension Length ("B" Dimension)
00	No Extension (For use with Code A, Direct Assembly, Only)
10	1.0 Inches [25.4 mm] (For use with Code E, Union extension, Only)
25	2.5 Inches [63.5 mm]
30	3.0 Inches [76.2 mm]
35	3.5 Inches [88.9 mm]
40	4.0 Inches [101.6 mm]
45	4.5 Inches [114.3 mm]
50	5.0 Inches [127 mm] (Maximum Length Allowed for Qualified Assemblies)
XX	Other - Consult Factory
	Code Head Connection (Instrument x Conduit)
A	1/2" Female NPT x 1/2" Female NPT
D	1/2" Female NPT x 3/4" Female NPT
X	Other - Consult Factory

8	J	25	D
---	---	----	---

Technical specifications

QDC model number configurator

880701	Generation 1 QDC	
Code Pin/Socket Configuration		
4	4 Pins/Sockets	
8	8 Pins/Sockets	
X	Other - Consult Factory	
Code Conductor Wire Gauge		
16	16 AWG Conductor Size	
18	18 AWG Conductor Size	
20	20 AWG Conductor Size (Standard size for most applications)	
X	Other - Consult Factory	
Code Connector Style		
B	Bayonet	
X	Other - Consult Factory	
Code Insulator Material		
P	PES (Polyethersulfone) or PEI (Polyetherimide)	
X	Other - Consult Factory	
Code O-Ring Material		
E	Nordel EPDM	
X	Other - Consult Factory	
Code Pin Side Potting		
3	EGS Type 3	
W	Ultra Electronics, Energy Potting	
X	Pin Side Not Supplied	
Code Pin Side Lead Wire or Cable		
F	Rockbestos Firewall III, XLPE (Standard)	
W	Ultra Electronics, Energy Supplied XLPE	
X	Pin Side Not Supplied	
Code Socket Side Potting		
3	EGS Type 3	
W	Ultra Electronics, Energy Potting	
X	Socket Side Not Supplied	
Code Socket Side Lead Wire or Cable		
F	Rockbestos Firewall III, XLPE (Standard)	
W	Ultra Electronics, Energy Supplied XLPE	
X	Pin Side Not Supplied	
Code SS Flexible Armor on Pin Side + Length		
000	No Armor	
XXX	Length to the nearest inch	
Code Cable or Wire Length on Pin Side		
000	Pin Side Not Supplied	
XXX	Length to the nearest inch	
Code SS Flexible Armor on Socket Side + Length		
000	No Armor	
XXX	Length to the nearest inch	
Code Cable or Wire Length on Socket Side		
000	Socket Side Not Supplied	
XXX	Length to the nearest inch	
880701 - 8 - 20 - B - P - E - 3 - F - 3 - F - 60 - 72 - 240 - 252		

Note: There is no Gen 3 QDC model number configuration. Contact the factory to obtain the specific Gen 3 model number.

Technical specifications

Terminal block wiring diagram

**6-WIRE
TERMINAL BLOCK**

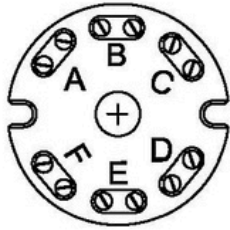

**SINGLE 4-WIRE
WIRING DIAGRAM**

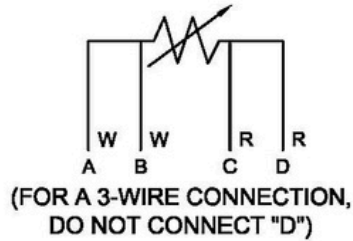

**8-WIRE
TERMINAL BLOCK**

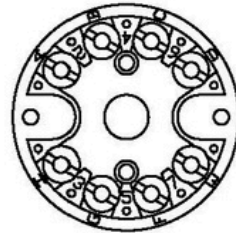

**DUAL 4-WIRE
WIRING DIAGRAM**

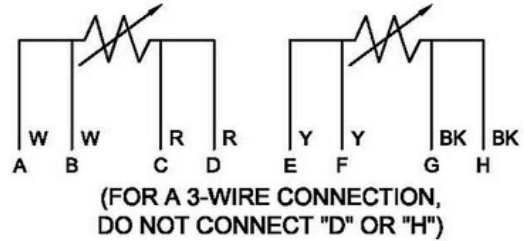

**DUAL 6-WIRE
WIRING DIAGRAM**

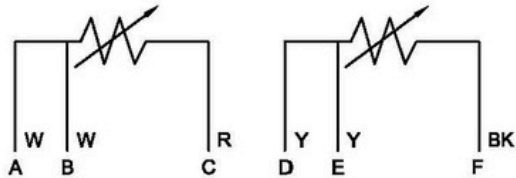

Technical specifications

QDC wiring diagram

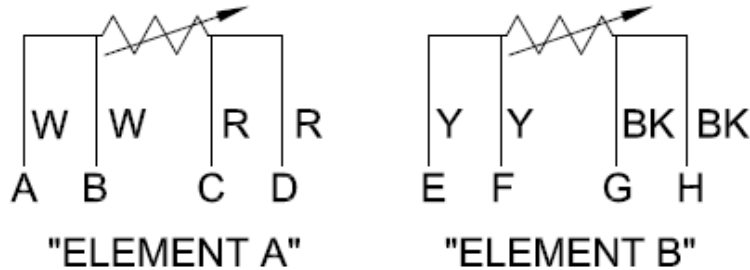

WIRING COLOR CODE

W = WHITE

R = RED

Y = YELLOW

BK = BLACK

NOTE:

- ELEMENT "A" - ELEMENT CLOSEST TO THE TIP WILL BE COLOR CODED AS RED & WHITE AND CONNECTED TO QDC PINS A, B, C & D.
- ELEMENT "B" - ELEMENT ABOVE ELEMENT "A" WILL BE COLOR CODED AS BLACK & YELLOW AND CONNECTED TO QDC PINS E, F, G & H.

CONNECTOR WIRING DIAGRAM

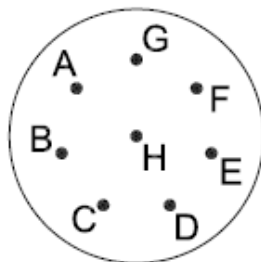

SOCKET BACKSHELL

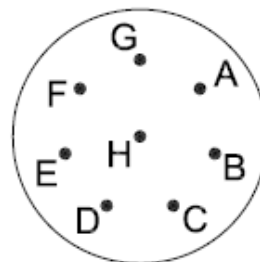

PIN BACKSHELL

FAQs

Can I specify my own required calibration points?

Yes. Calibration at ice point (32°F/0°C) and boiling point (212°F/100°C) are required to determine the appropriate Alpha temperature coefficient. Up to 4 additional calibration points at higher temperatures can be specified. Data from only 3 of the actual calibration points (32°F/0°C, 212°F/100°C and a select third point) will be used to generate a custom temperature versus resistance table using the Callendar-Van Dusen equation.

Can the 611 RTD be ordered to meet special accuracy needs?

Yes. Please contact sales with the specific requirements so we may determine if we can meet your needs.

Can I use a protection tube or thermowell with the 611 RTD?

Yes, but the tip of the RTD will not contact the bottom of the thermowell or protection tube resulting in slow response time. When using a thermowell or protection tube, it is recommended to use a model 612 or model 615 spring-loaded RTD assembly.

About Ultra Energy

Organizations working with nuclear and industrial technologies must deliver reliable production at the same time as safeguarding people, the environment and infrastructure. We develop and manufacture measurement and control solutions that give our customers complete, long-term control over systems operating in harsh environments, helping them operate safely and increasing the value derived from their investments over their total lifespan.

Part of Curtiss-Wright, Ultra Energy has worked with nuclear and industrial customers for over 60 years. We support customers across the world from facilities located in the US and UK. Our solutions are embedded in strategic national infrastructure and our people are active partners in customer programs that are focused on delivering advanced future nuclear and industrial capabilities.

United States of America

707 Jeffrey Way
Round Rock
Texas 78665-2408
USA

Tel: +1 512-434-2800

United Kingdom

Innovation House
Lancaster Road
Ferndown Industrial Estate
Wimborne
Dorset BH21 7SQ
UK

Tel: +44 (0) 1202 850 450

For more information

Web: ultra.energy

Email: sales@ultra.energy