

NP9000 extreme environment pressure transducers



Key features

- Absolute pressure transducer
- Operating temperature to 650°F
- Remote operation up to 250 feet between transducer and electronics
- Magnetic field immunity
- Fully submersible
- 100% analog passive component / simple apparatus
- Compatible with our analog pressure transmitter electronics and strain gauge signal converters

Overview

The NP9000 Series pressure transducers are the latest generation of harsh environment sensors designed and manufactured by Ultra Energy. These fully hermetic submersible transducers combine a Wheatstone bridge strain gauge pressure sensor and a temperature sensor. This allows for precise temperature compensation in the signal conditioner or transmitter electronics. The transducer is manufactured using a proprietary process with high temperature interconnects. Mineral insulated metal sheathed cable carries power and signals for connection to remote signal conditioners. The transducer is a fraction of the size of industrial pressure transmitters making it ideal for on-machine applications in extreme environments where traditional pressure transmitters are unsuitable. Signal converters can be located up to 250 feet away in a mild environment. No other pressure transducer can match the extreme temperature performance of the NP9000.

Technical specification

Feature	Description
Function	Harsh Environment absolute pressure transducer with temperature compensation
Ingress protection	Fully hermetic and submersible (1000 psi external pressure withstand)
Pressure ranges 0-URL (psia)	0-20, 0-100, 0-1500, 0-2500
Overpressure	2 x URL max
Burst	4 x URL min
Operating range	+40°F to +650°F (survival at +665°F for one hour)
Reference accuracy*	±0.25% URL at 25°C
Linearity	< 0.2% FS
Response time	≤ 0.4 sec
Ambient temperature effect*	±0.5% of URL / 100°F
Total accuracy (reference accuracy, ambient temperature effect, 24-month drift)*	±2.5 % of URL @300°F ±50°F
Total uncertainty (degraded conditions, DBA/LOCA, PAM)*	±5.2 % of URL
Materials	Stainless Steel 316/316L with 15-5 PH or Inconel diaphragm sensor
Process connection	JIC Fitting (JIC 37°) 7/16"-20 UNJF-3A thread per MS33656-4

Technical specification

Feature	Description
Cable	Harsh environment six-conductor mineral insulated metal sheathed cable, 1/4" O.D.
Electrical	4-wire closed bridge + 1 or 2 wire RTD for temperature compensation
Bridge	4-wire 5,000 – 10,000 kΩ
Sensitivity	2 mV/V nominal
Bridge excitation	10 – 20 VDC
Insulation resistance	IR: >100 MΩ @ 50 VDC
Temperature sensor	1,000 Ω Pt 3850 ppm/K RTD or 300 Ω 5000 ppm/K
Environmental	IEEE Class 1E capable up to Safety Class A1, Seismic Cat I
Mission life	≥ 24 months; ≥ 35Mrad TID
Quality class	Nuclear grade quality assurance
Conformity	ASME Section III, ANSI/ISA-67.02.01-2014 Nuclear Safety-Related Instrument Sensing Line Piping and Tubing Standard
Weights	<ul style="list-style-type: none"> • Bracket 2.4lbs • Pressure Transducer 0.8lbs • Swagelok® NVT4N5VG15-GR two-stem manifold 2.7lbs • Manifold Mounting bolts 0.3lbs • Swivel Nut Male Connector – SAE 37° Flared adapter 0.1lbs • U-Bolt 0.3lbs • Total Assembly w/o MI Cable 6.5lbs • MI Cable @ 0.11 Lbs/Ft

Technical specifications

Schematic of bridge

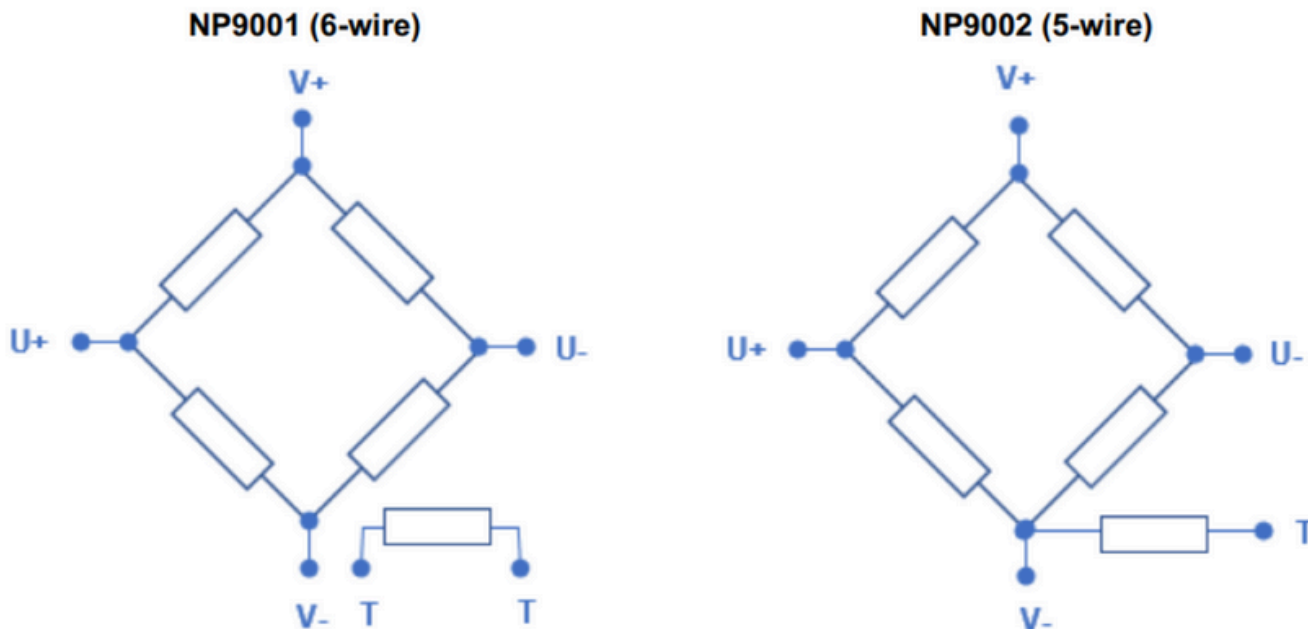

Pinout	NP9001	NP9002
1	V+	V+
2	T	NC
3	T	U-
4	U-	V-
5	V-	T
6	U+	U+

V+ and V-: Supply Voltage
 U+ and U-: Signal
 T: Temperature

Ordering information

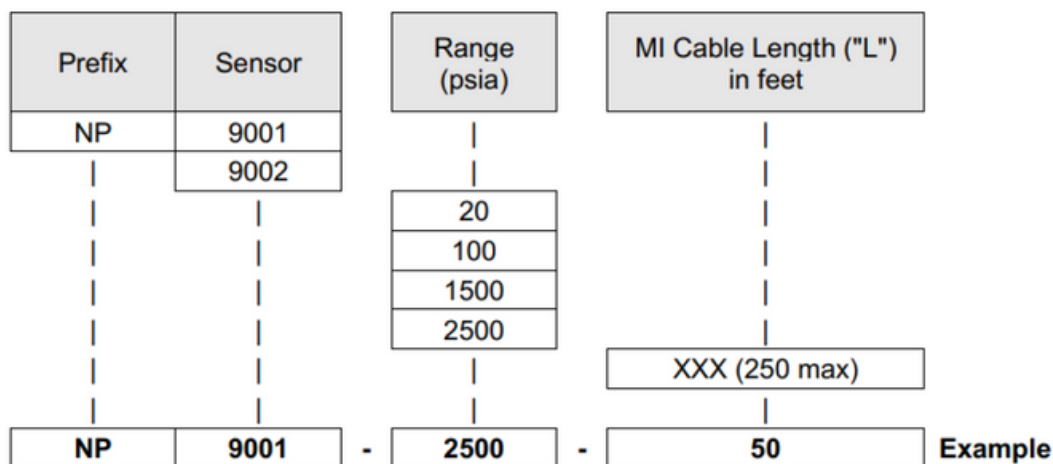

About Ultra Energy

Organizations working with nuclear and industrial technologies must deliver reliable production at the same time as safeguarding people, the environment and infrastructure. We develop and manufacture measurement and control solutions that give our customers complete, long-term control over systems operating in harsh environments, helping them operate safely and increasing the value derived from their investments over their total lifespan.

Part of Curtiss-Wright, Ultra Energy has worked with nuclear and industrial customers for over 60 years. We support customers across the world from facilities located in the US and UK. Our solutions are embedded in strategic national infrastructure and our people are active partners in customer programs that are focused on delivering advanced future nuclear and industrial capabilities.

United States of America

707 Jeffrey Way
Round Rock
Texas 78665-2408
USA

Tel: +1 512-434-2800

United Kingdom

Innovation House
Lancaster Road
Ferndown Industrial Estate
Wimborne
Dorset BH21 7SQ
UK

Tel: +44 (0) 1202 850 450

For more information

Web: ultra.energy

Email: sales@ultra.energy