

# DTN2070

## absolute and gauge pressure transmitter



### Key features

- Advanced thin film metal strain gauge sensor technology
- Stainless steel housings, non-painted
- Seismically qualified stainless steel mounting brackets
- Loop powered, 2 wire, 4-20 mA
- Quarter inch NPT process connections
- Dustproof and waterproof construction, no humidity effect

### Overview

Ultra Energy's DTN2070 Class 1E absolute and gauge pressure transmitters are designed to provide reliable and precise pressure measurements in nuclear applications operating in harsh environments. It meets the most stringent environmental requirements of Gen III+ reactors for harsh operating environments and post-accident monitoring applications inside containment. The DTN2070 contains only analog electronics, using a diaphragm isolated direct coupled strain gauge pressure sensor capsule. The DTN2070 has undergone complete seismic and environmental qualification, being Class 1E qualified to IEEE 323-1974 and IEEE 344-1987.

## Technical data

Feature	Description
Reference accuracy	±0.25% of span, typical < 0.15%, includes linearity, hysteresis, deadband, settability and repeatability
Stability/drift	±0.25% of URL per 30 months at reference conditions
Zero overpressure effects (per 1000 psi/6.89 Mpa)	±0.25% URL one-sided, ±1% URL two-sided sequential
Field adjustability (zero and span) for harsh environment models	±15% of span, within the transmitter URL
Field adjustability (zero and span) for non-safety, mild and non-submergence models	Zero: ±70% of URL, Span: ±33% to ±100% of URL
Direct or reverse acting capabilities	Factory set and can't be changed in the field
Zero elevation, zero suppression factory set	Zero elevation and suppression must be such that neither the calibrated span nor the upper or lower range value exceeds 100% of the URL
Range-down	3.5 to 1 (minimum span is 28.6% URL)
Operating temperature	40°F to 257°F (4.4°C to 125°C) normal services. Operating temperatures will affect qualified life
Storage temperature	-40°F to 257°F (-40°C to 125°C). Storage temperatures above 120°F will affect qualified life.
Output signal	4-20 mA two wire only
Response time (all range codes)	≤0.2 sec; sensor response time to 50% with a 100% span step change at 100°F (37.8°C)

## Technical data

Feature	Description
Damping	Factory set, 0 or 1.6 seconds
Power supply effect	0.005% of calibration span/volt
Min current limit	3.4 +/- .1 mA
Max current limit	21.6 +/- .2 mA
Power supply load limitations	18 VDC to 48 VDC (mild); 18 VDC to 33 VDC (harsh); R ( $\Omega$ ) = maximum field loop resistance = 45.5 * (power supply voltage - 18)
Load effect	Within limits set by the line voltage, the output current is independent of load resistance
Mounting position effect	No span effect; zero shift of up to 1.5 inH <sub>2</sub> O (0.249 kPa) which can be calibrated out
EMC/EMI compliance	Satisfies requirements defined in: US NRC Reg. Guide 1.180 Rev. 1. European EMC Directive 2014/30/EU by conforming to applicable EN and IEC Standards: compliance testing to the EN 61000 Series standards, CE marking, declaration of conformity
Transient protection	Meets Criteria A of IEC 61000-4-4:1995 (electrical fast transient/burst immunity test; power and I/O line burst: 2kV, 15/300 ms, 5kHz)
PED and CE mark	Fully compliant
Temperature effects (per 50°F/ 27.8°C)	Above 130°F (54.4°C), determine the error from 130°F to the temperature of interest then add the 130°F error.

## Technical data

Feature	Description
Harsh Environments 40°F to 130°F (4.4°C to 54.4°C)	±0.8% URL + 0.3 % span
Harsh Environments 130°F to 257°F* (54.4°C to 125°C)	±0.52% URL + .25% Span; (see note above, temperature effects above 130°F)
Mild, rad harsh and submergence 40°F to 130°F (4.4°C to 54.4°C)	± 0.50% URL
Power supply requirements	18 VDC to 48 VDC (see also 'DTN2070 power supply load limits' later in this document for load resistance requirements.)
Volumetric displacement	Negligible
Enclosure rating	NEMA 6P (IP 68)
Humidity Limits	0-100% RH, submergence
Turn-on time	2 seconds or less, 1 minute for rated accuracy
Isolating diaphragms	All range codes: Stainless 15-5 PH
Drain vent valve	None
Process flange	316 SST
Process seal	EPDM
Electronics housing O-ring	EPDM
Fill fluid	None (vacuum)

## Technical data

Feature	Description
Sensor module and electronics housing	316 SST
Mounting bracket and bolts	304 SST
Process connections	1/4-18 NPT Optional: welded fittings
Electrical connections	Gen 3 Quick Disconnect Connector (QDC); seal gland with 8 feet leads
Weight	9.2 lbs. (4.17 kg) including integral mounting bracket
Traceability	Per 10CFR50 Appendix B, 10CFR21, NQA-1, and ISO 9001:2008; chemical and physical certification of pressure retaining parts.
Service Life	23.4 years at 100° F (37.8°C) (see 'Qualified service live vs. temperature' towards the end of this document for details.)
Seismic accuracy	Specifications listed reflect maximum error during seismic disturbance. All ranges: accuracy within $\pm 0.5\%$ URL for OBE at 1/2 SSE, accuracy within $\pm 0.7\%$ URL for SSE Transmitters will return to within $\pm 0.20\%$ after the event. (see 'Seismic - Test Response Spectra, 5% Damping' towards the end of this document tab for details.)
During LOCA	+ 4.0 % of URL for DPs +3.7 % of URL for PAVPGs First 15 days and submergence, excludes radiation (See 'Actual LOCA/PAMS chamber temperature' towards the end of this documents for details.)
During PAMS	+ 2.7% of URL 43 days
Environmental/seismic qualifications	IEEE 323-1974 and 323-1983, IEEE 344-75 & IEEE 344-87

## Technical specifications

### Model updates

The transmitter has been updated over the years to improve performance and to deal with component obsolescence. The sensing capsule of the DTN2070 - Westinghouse Veritrak/ Tobar/ Camille Bauer Model 32, and most recently Weed Instrument DTN2010 and N97 - has the same field-proven, underlying design as the Model 32 originally qualified in 1982.

### Service life vs. temperature

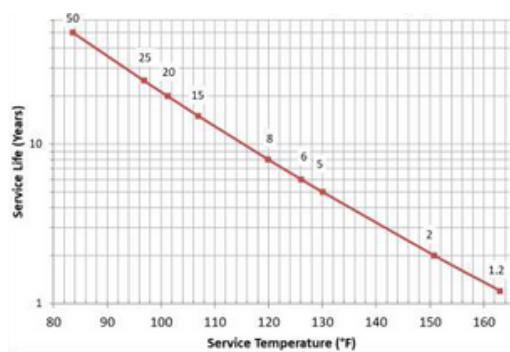
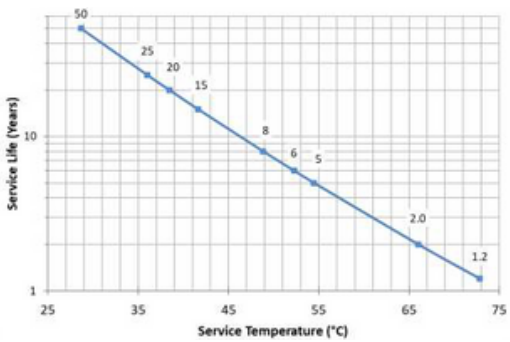

### Ranges and limits

#### Imperial Units

DP	Range Code	Diaphragm Material	URL inH2O @20°C	Span Range inH2O	Static Pressure / Overpressure Limit
	200	Hastelloy - C	40	11 to 40	
300	Hastelloy - C	100	29 to 100		
400	Hastelloy - C	250	71 to 250		
600	Stainless 17-7PH	650	31 to 650		
800	Stainless 17-7PH	800	229 to 800		
850	Hastelloy - C	956	273 to 956		
100 <sup>†</sup>	Hastelloy - C	100 psi	29 to 100 psi		

#### Metric Units<sup>¶</sup>

DP <sup>¶</sup>	Range Code <sup>¶</sup>	Diaphragm Material <sup>¶</sup>	URL <sup>¶</sup> kPa <sup>¶</sup>	Span Range <sup>¶</sup> kPa <sup>¶</sup>	Static Pressure / Overpressure Limit <sup>¶</sup>
	200 <sup>¶</sup>	Hastelloy - C <sup>¶</sup>	9.95 <sup>¶</sup>	3 to 9.95 <sup>¶</sup>	
300 <sup>¶</sup>	Hastelloy - C <sup>¶</sup>	25 <sup>¶</sup>	7 to 25 <sup>¶</sup>		
400 <sup>¶</sup>	Hastelloy - C <sup>¶</sup>	62 <sup>¶</sup>	18 to 62 <sup>¶</sup>		
600 <sup>¶</sup>	Stainless 17-7PH <sup>¶</sup>	162 <sup>¶</sup>	46 to 162 <sup>¶</sup>		
800 <sup>¶</sup>	Stainless 17-7PH <sup>¶</sup>	199 <sup>¶</sup>	57 to 199 <sup>¶</sup>		
850 <sup>¶</sup>	Hastelloy - C <sup>¶</sup>	238 <sup>¶</sup>	68 to 238 <sup>¶</sup>		
100 <sup>†</sup> <sup>¶</sup>	Hastelloy - C <sup>¶</sup>	689 <sup>¶</sup>	197 to 689 <sup>¶</sup>		

### Power supply load limitations, 4-20 mA

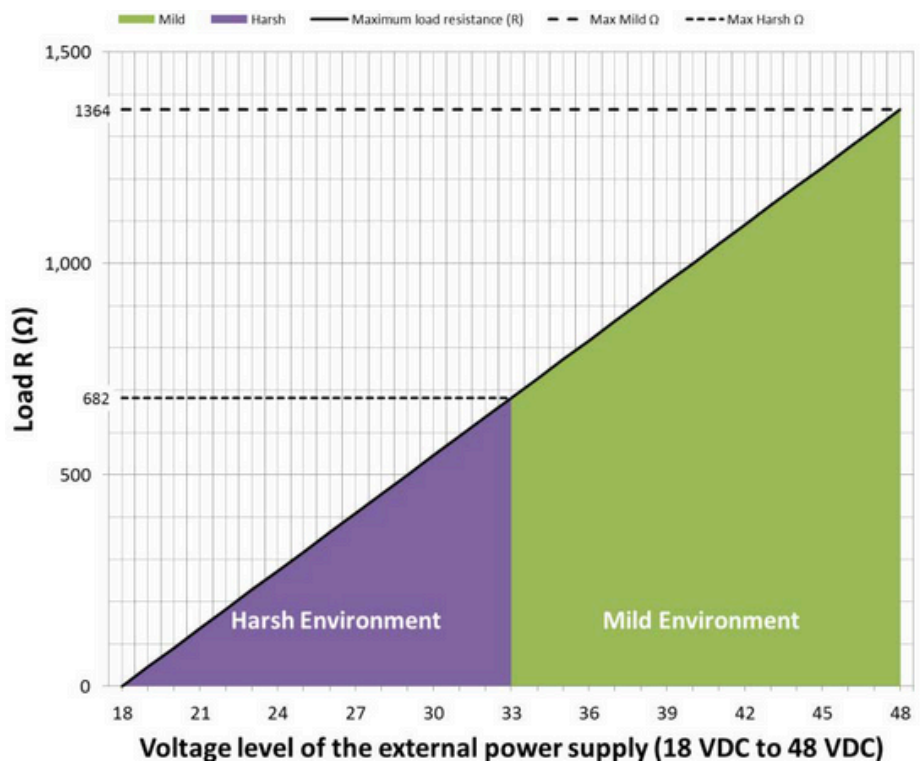

# Technical specifications

Seismic test response spectra, 5% damping

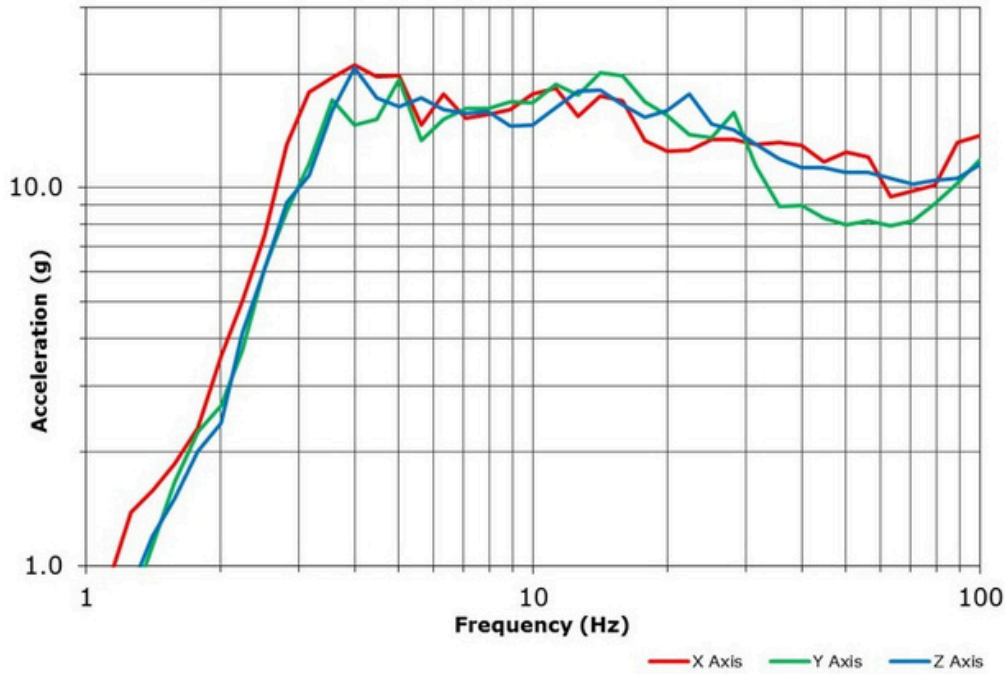

Seismic – Test Response Spectra, 5% Damping.

Actual LOCA/PAMS chamber temperature

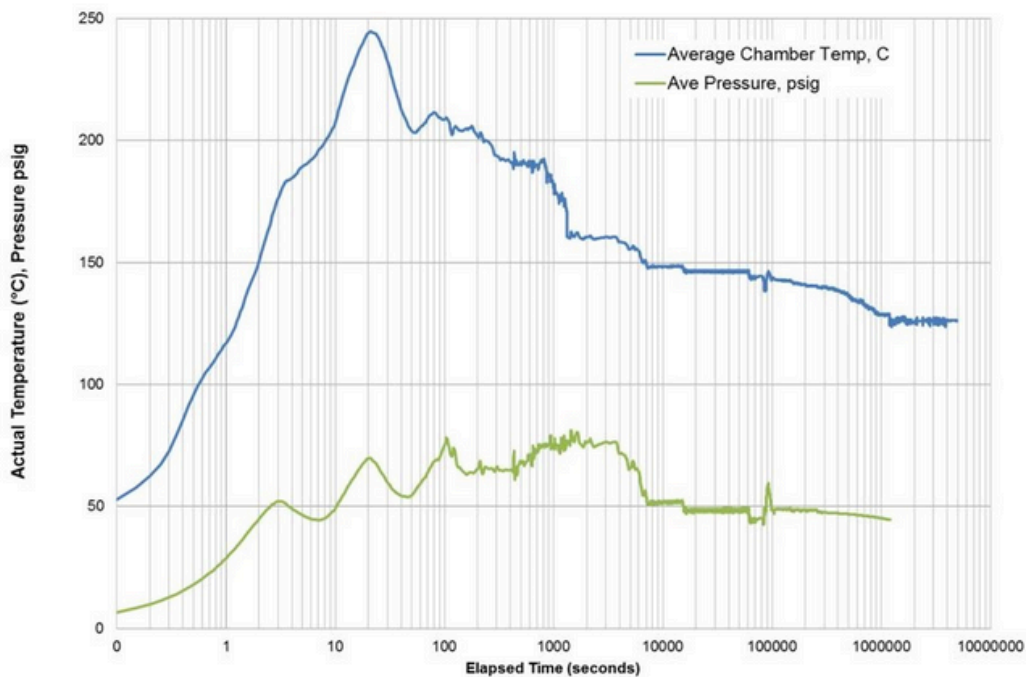

## Technical specifications

### Dimensional drawings

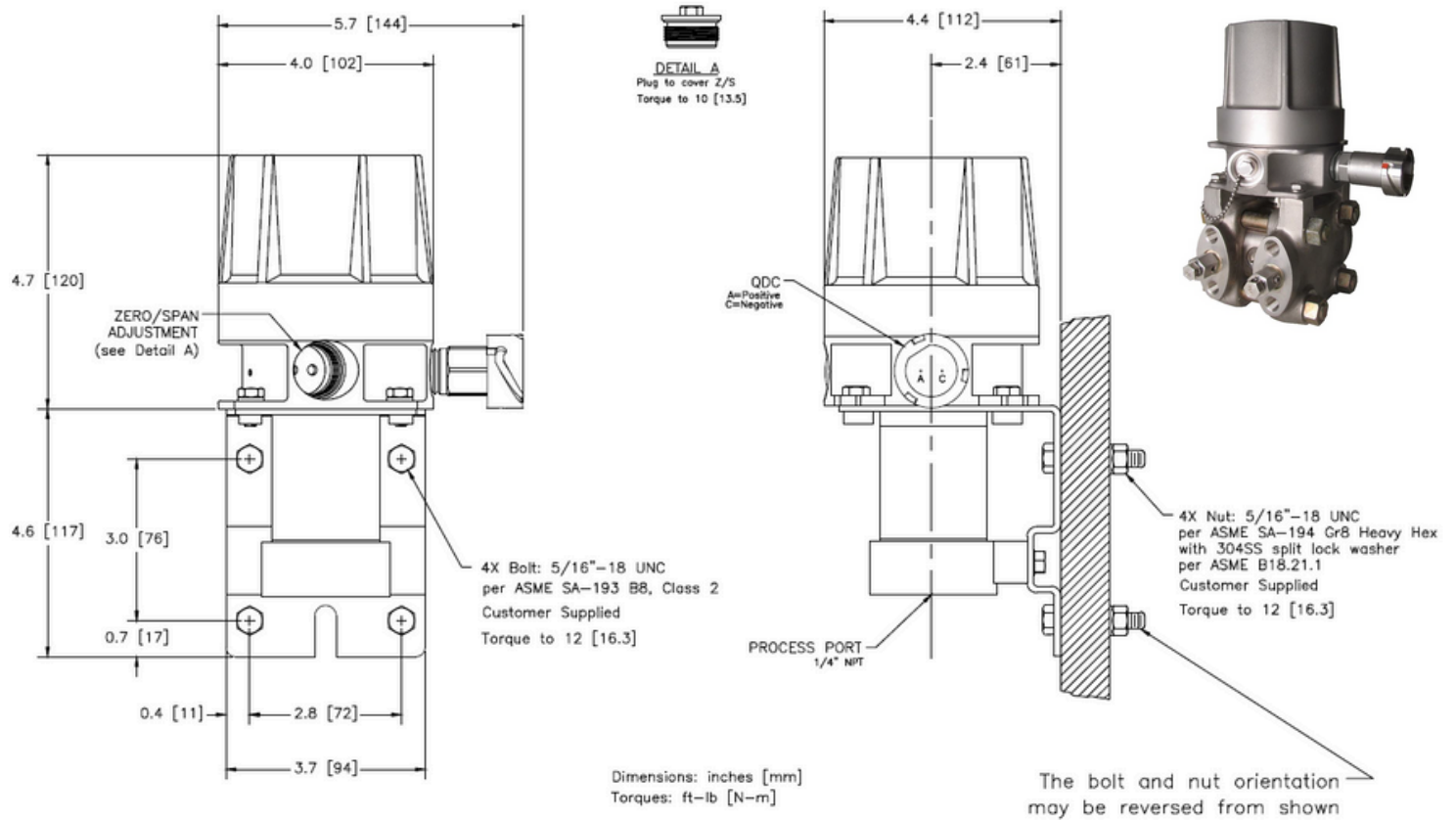



# Technical specifications

## Model matrix

DTN2070											
	Transmitter Type										
	DP	Differential Pressure									
	•	Output Action									
	•	D	Direct Acting output (default)								
	•	R	Reverse Acting Output								
	•	•	Model Range Code								
	•	•		Capsule URL	Units						
	DP	•	200	40	DP	inH2O					
	DP	•	300	100	DP	inH2O					
	DP	•	400	250	DP	inH2O					
	DP	•	600	650	DP	inH2O					
	DP	•	800	800	DP	inH2O					
		Transmitter Type									
	PA	Absolute Pressure									
	PG	Gauge Pressure									
	•	Output Action									
	•	D	Direct Acting output (default)								
	•	R	Reverse Acting Output								
	•	•	Model Range Code								
	•	•		Capsule URL	Units						
	•	•	240	50	PA/PG	psia/g					
	•	•	440	200	PA/PG	psia/g					
	•	•	540	500	PA/PG	psia/g					
	•	•	740	1500	PA/PG	psia/g					
	•	•	840	2500	PA/PG	psia/g					
	•	•	940	6000	PA/PG	psia/g					
	•	•	•	Electrical Connection							
	•	•	•	G	EGS Quick disconnect connector						
	•	•	•	L	Flying Leads, 96 inches						
	•	•	•	•	<b>OPTIONS</b>						
	•	•	•	•	Electrical Connections, Field Side						
	•	•	•	MX	X feet of field side cable.						
	•	•	•	•	Mounting						
	•	•	•	•	A	Wall mount , DP only, (mounting bracket is integral on PA/PG )					
	•	•	•	•	•	Remote Seals/capillaries					
	•	•	•	•	SX	X feet capillary, water filled   Consult Factory					
	•	•	•	•	•	Special Materials of Construction					
	•	•	•	•	•	H	Consult Factory				
	•	•	•	•	•	•	Process Connection				
	•	•	•	•	•	FS	Special				
	•	•	•	•	•	•	Other Specials				
	•	•	•	•	•	•	SP   Consult Factory				
DTN2070	PG	D	941	G							Sample Model Number

## About Ultra Energy

Organizations working with nuclear and industrial technologies must deliver reliable production at the same time as safeguarding people, the environment and infrastructure. We develop and manufacture measurement and control solutions that give our customers complete, long-term control over systems operating in harsh environments, helping them operate safely and increasing the value derived from their investments over their total lifespan.

Part of Curtiss-Wright, Ultra Energy has worked with nuclear and industrial customers for over 60 years. We support customers across the world from facilities located in the US and UK. Our solutions are embedded in strategic national infrastructure and our people are active partners in customer programs that are focused on delivering advanced future nuclear and industrial capabilities.

## United States of America

707 Jeffrey Way  
Round Rock  
Texas 78665-2408  
USA

Tel: +1 512-434-2800

## United Kingdom

Innovation House  
Lancaster Road  
Ferndown Industrial Estate  
Wimborne  
Dorset BH21 7SQ  
UK

Tel: +44 (0) 1202 850 450

## For more information

Web: [ultra.energy](http://ultra.energy)

Email: [sales@ultra-nspi.com](mailto:sales@ultra-nspi.com)