

CC-TS13H fiber optic transmitter

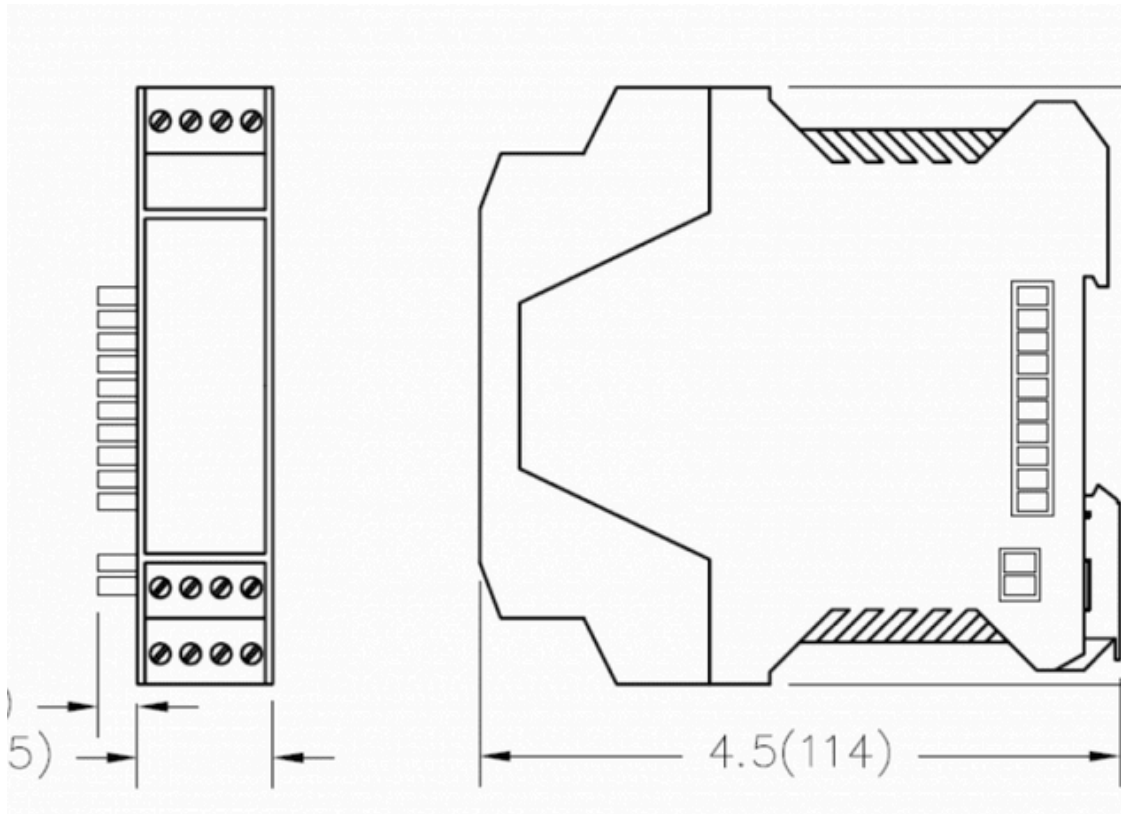

Feature	Description
Module type	Transmitter (Hi-power)
Channels	2
Optical wavelength	1300nm

Technical specification

Feature	Description
Optical mode	Single mode
Optical dynamic range	16dB
Power requirements	7.5Vdc via the BUS interconnections (from any EOTec 2000 power supply module) or 12 to 30Vdc at 400mA, via a pluggable, screw terminal block on the CC-T/CC-R module
Relay contact output	SPDT Form C relay, via a pluggable, screw terminal, 12 to 24 AWG (0.5-2.4mm) cage-clamp 60W, 125VA, maximum switching voltage 2A switching, 3A carry, maximum current 100,000,000 cycles, minimum operational life
Contact closure input	External dry contacts connected via pluggable, screw terminal blocks, accepts 12 to 24 AWG, 5Vdc @ 1.4mA minimum contact rating, 1K ohm maximum resistance
LED status indicators	Power on green, channel A relay energized/input contact closed green, channel B relay energized/contact input closed green, fiber transmit - amber
Data update rate	15ms regardless of the number of channels utilized
Ambient conditions	-40 to 85°C operational
Weight	< 9oz (250g)
Accessory	I/O module CC-I, CC-O

About Ultra Energy

Organizations working with nuclear and industrial technologies must deliver reliable production at the same time as safeguarding people, the environment and infrastructure. We develop and manufacture measurement and control solutions that give our customers complete, long-term control over systems operating in harsh environments, helping them operate safely and increasing the value derived from their investments over their total lifespan.

Part of Curtiss-Wright, Ultra Energy has worked with nuclear and industrial customers for over 60 years. We support customers across the world from facilities located in the US and UK. Our solutions are embedded in strategic national infrastructure and our people are active partners in customer programs that are focused on delivering advanced future nuclear and industrial capabilities.

United States of America

707 Jeffrey Way
Round Rock
Texas 78665-2408
USA

Tel: +1 512-434-2800

United Kingdom

Innovation House
Lancaster Road
Ferndown Industrial Estate
Wimborne
Dorset BH21 7SQ
UK

Tel: +44 (0) 1202 850 450

For more information

Web: ultra.energy

Email: sales@ultra.energy